

# SMITH CARREL, INC.

Call Toll Free 1-877-410-6994 or Fax 972-272-7208

## Kiosk Carrel w/ Printer Shelf & CPU Holder





**Shown: #02385D Kiosk in Grey Nebula**

**AVAILABLE AS A STARTER UNIT ONLY**

**DESIGNED BY REQUEST!!!**

Since the inception of the Hi-Lo Carrel in 2008, Smith Carrel has had numerous requests for a standing height unit with space for a printer. This adjustable height Kiosk offers a totally complete stand-alone work station with privacy. The model #02385 is 32.5"W x 30"D, and with a standing work surface height of 39" adjustable to a low of 27" in 1" increments. The printer/CPU holder shelf has 15.75" height clearance and is 22.75" deep and

 Click on any photo to enlarge!  
 **Print this page!**

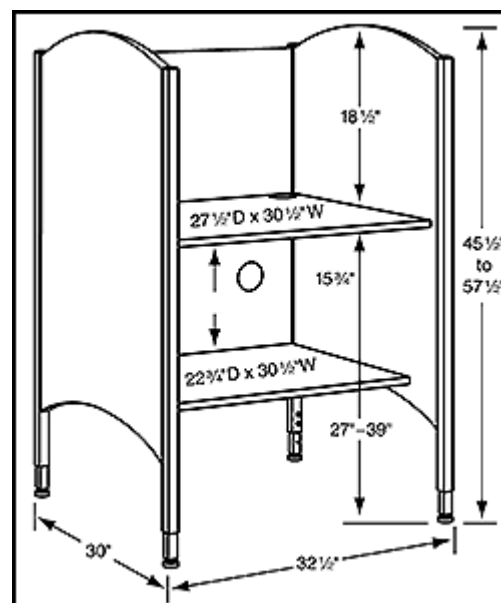

**Kiosk Dimensions**

**Overall:**  
**30"D x 32 1/2"W x**  
**46 1/2"H to 57 1/2"H**

Freight Class: **70**  
 Shipping Location: **75042**

**Adjustable height work surface:**  
**27" - 39"**

**MODEL NUMBERS**  
*Available as a starter only!*

*Adjustable Height: 27"-39"*

<b>02385 Kiosk Carrel</b>	
---------------------------	--

31.5" wide. Wiring grommets are standard.

Weight:	136
Cube:	4.72



 Click on any photo to enlarge!

 **Print this page!**



**#02385G Kiosk in Wild Cherry**



**Shown: #02385H Kiosk in Fusion Maple**

**Color Choices**

*Add color suffix to model number*

Feet or lower legs of adjustable models are always chrome.

<b>Specify Suffix</b>	<b>Panels &amp; Shelf</b>	<b>Work Surface</b>	<b>Corner Post Legs</b>
<b>D</b>	GREY NEBULA	GREY NEBULA	BLACK
<b>G</b>	WILD CHERRY	WILD CHERRY	BLACK
<b>H</b>	FUSION MAPLE	FUSION MAPLE	BLACK



**Grey Nebula**

**Wild Cherry**

**Fusion Maple**

*Actual colors may vary*

**Product Specifications - Kiosk w/ Printer Shelf**

**Surface and Panels**

Are 3/4" thick solid core construction in low glare thermofused melamine laminate with PVC edge banding. Side panels are arched both top (convex) and bottom (concave) for aesthetics.. Includes a 22 3/4"D x 31 1/2"W Printer and CPU Holder Shelf under the work surface with 15 3/4" height clearance for large CPU's. Also equipped with (2) 3" diameter cable grommets for wiring. The work surface front edge is 3mm soft radius PVC for arm comfort.

**Frame**

Includes four 1 1/4" square 14-gauge steel corner post legs with black baked on powder coat finish. Legs are equipped with 1" square 14-gauge adjustable leg stems that allow the work surface to be moved in 1" increments from the height of 27" to a kiosk height of 39"! Legs also include 1" leveling glides for a sturdy and level fit to the floor. Ships ready to assemble.

**Accessories for Kiosk**

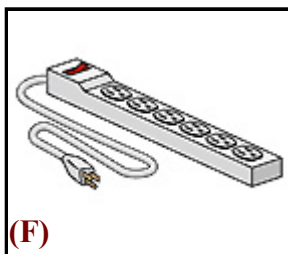

Model	Accessory Description	Wt.	Cube
<b>(F) 01650</b>	6 Outlet Surge Protected Power Strip	2	.10
<b>(L) 01532</b>	Power Module w/10' Power Cord	2	.10

Info & Support: [info@smithcarrel.com](mailto:info@smithcarrel.com)      [Home](#)      Sales: [sales@smithcarrel.com](mailto:sales@smithcarrel.com)

© 2008-15 Smith Carrel, Inc. All rights reserved. **Terms of Use**  
 (NOTE: Computers and related equipment and photo props are not included.)